

# Laser Sight

Model: GM-1040A

## USER MANUAL

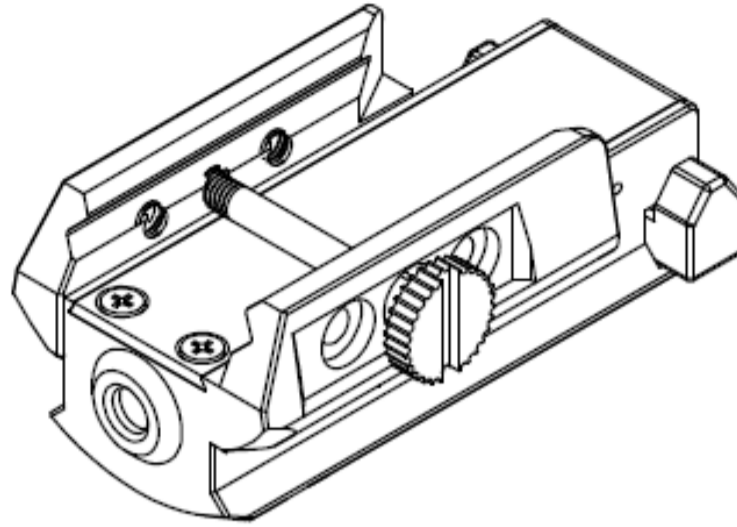

Thank you for purchasing this Laser Sight Product.  
Please read this manual carefully before use and keep it for future reference!!

---

### Features:

1. Built-in battery, Magnetic USB charging.
2. Compact, lightweight and portable design.
3. Fit for universal railed mounted pistol.

### Structure Overview:

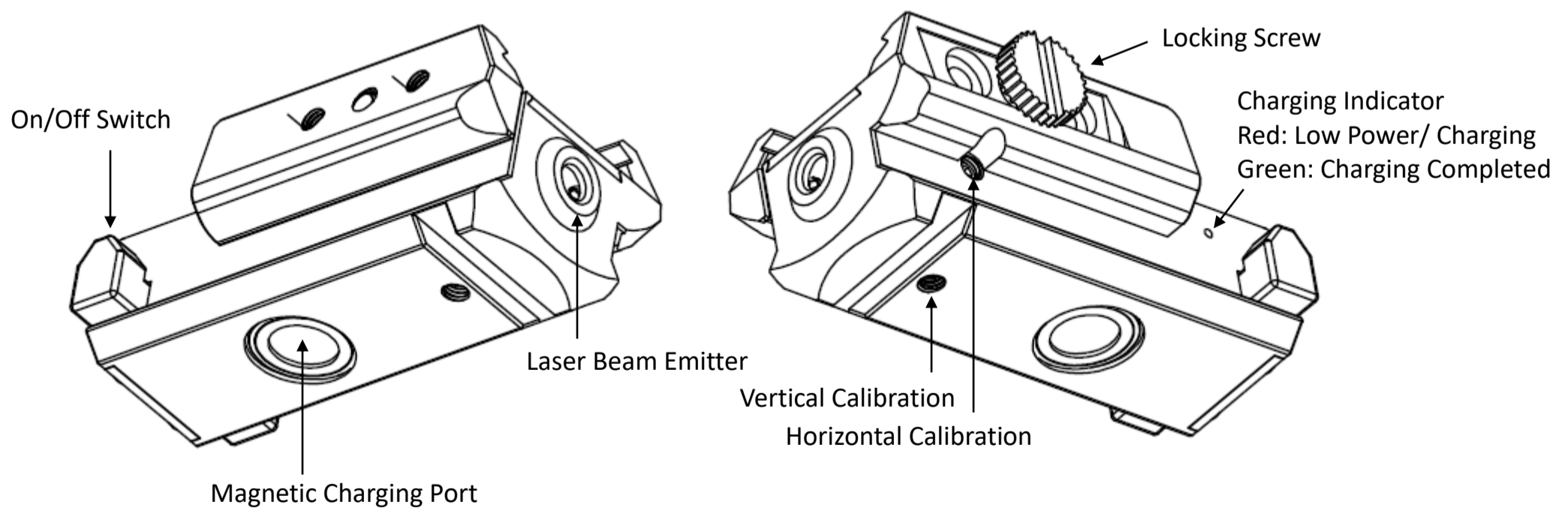

## Specifications:

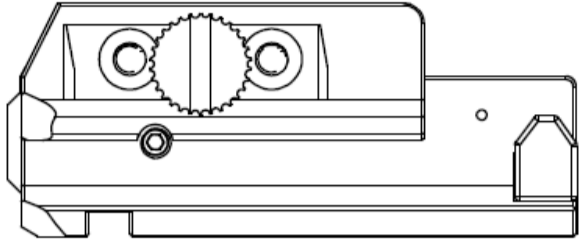
			
Wavelength	Green: 520nm	Red: 650nm	Blue: 450nm
Battery Source	Polymer Battery (Built-in)		
Max Output Power	<5mW		
Waterproof Rating	IPX4		
Weight	50 g		
Running Time	1.5 hr		
Charging Time	1.5 hr		

\*\*\* The power measurement is performed when the built-in battery is fully Charged.

## Delivery Sets:

- Laser Sight x 1
  - Allen Wrench x 1
  - Magnetic USB Charging Cable x1
  - Metal Sheet x1
  - User Manual x1
- 

## Operating:

1. Press the switch button to turn the laser on.
2. Press the switch button again to turn the laser off.
3. Ambidextrous On/Off switches on both sides.

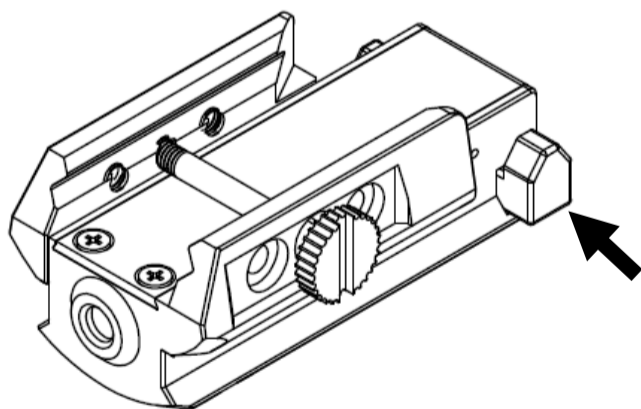

## Charging:

**WARNING:** After first checking to insure that firearm is unloaded has no ammunition in the chamber.

This gun sight is powered by a built-in rechargeable battery, which is charged with a Magnetic USB charging Cable, it can be charged by 5V chargers, such as Computer/Laptop USB ports, phone/tablet chargers etc.

- \*\*\* Low power/charging— Indicator is red
  - \*\*\* Fully charged— Indicator is constantly green
-

## Mounting:

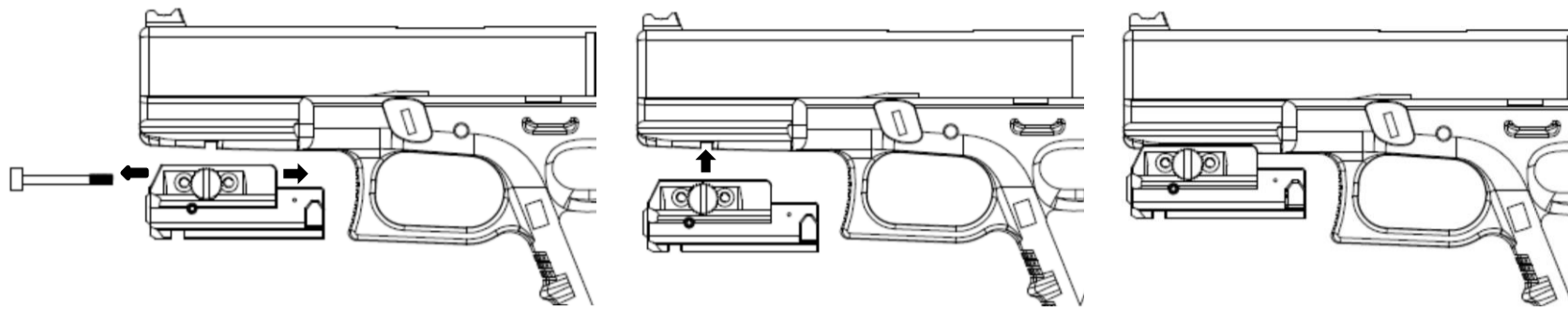

Choose one of the holes for the screw to get forward/backward location, only one screw is needed.

Loosen the mounting screw and push it, the rail system will be extended, fix the screw into rail's groove.

Tighten the screw to finish the installation.

## Zero Adjustment:

1. Fix the laser sight to the barrel on a firearm.
2. Place the firearm in a vise or on a shooting bench.
3. Place a target about 30m away.
4. The next step assumes that the firearm's iron sights or other sighting system is correctly zeroed for 30m. If not, turn the laser off and fire 5 rounds at the target to see the point of impact grouping. If necessary, adjust your sights to the correct point of impact.

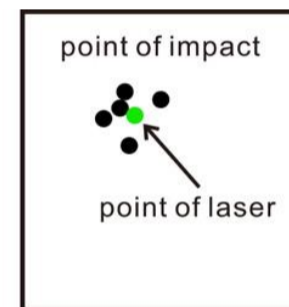
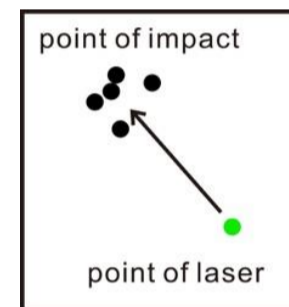

5. Take aim again using the exact same sight picture as in step#4. Turn on the laser sight and you will see the difference in distance between the laser dot and the real point of impact. To adjust the laser to be point of impact the windage and elevation will need to be adjusted. Rotating the windage and elevation with Allen wrench to adjust the laser.
6. Now use the laser sight, aim at the target, and shoot another group of 5 rounds. If the point of the laser is near the points of impact, then the Zero adjustment has been accomplished.

## Warranty:

This product is free from defects in materials and workmanship. Within 15 days after receipt, any defective product will be offered free replacement by the manufacturer unconditionally. We will repair or replace, at its option and without charge, any product or part which is found to be defective under normal use and service with 12 months counting from the date of purchasing with the proof of purchase. This warranty does not cover normal maintenance and service and does not apply to any product or part which has been subject to modification.

## Warning:

Before beginning the adjustment process, insure that your weapon is unloaded and there is no ammunition in the chamber.  
During laser alignment make sure to always keep your weapon pointed in a safe direction away from others and never place your finger on the trigger,  
Direct viewing of the laser is hazardous to the eyes.  
Never look directly into the laser beam.  
Never point laser beam at a person.  
Do not allow children to use laser sight unless under adult supervision.



Laser beam is forbidden to shoot eyes and skin directly, blindness and burn will be caused.