

BORE SIGHT KIT USER MANUAL

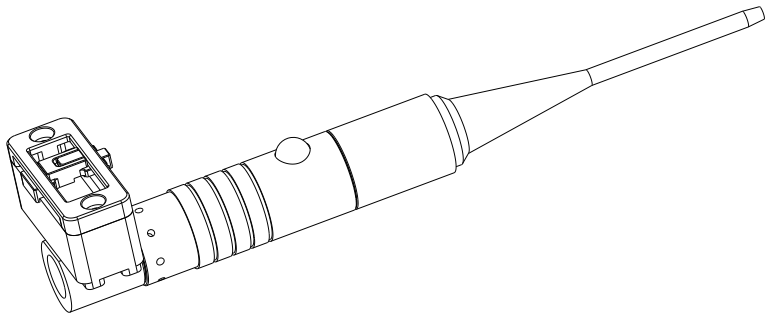

Thank you for purchasing this bore sight kit. Please keep this manual for future reference.
You will likely use it again and again as your first step towards "Accuracy".

Our Bore Sight Package Includes:

1 x Boresighter

32 x Different Caliber Adapters

2 x CR2 800mAh Batteries

1 x Arbor

1 x Screwdriver

1 x Allen Wrench

1 x Spare Screw

1 x Instruction Manual

1 x Storage Case

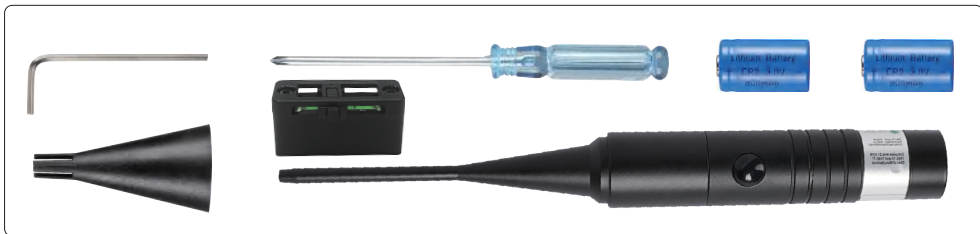
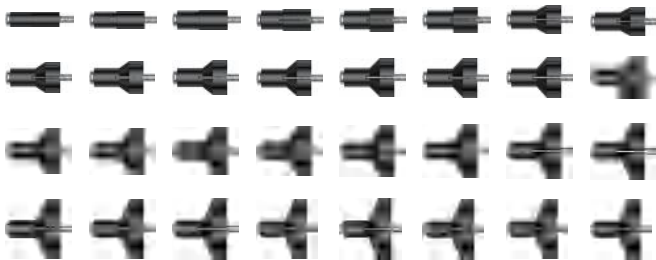

Specification:

Material:	Aluminum	Max. Output Power:	<5 mW
Laser Class:	IIIA laser	Battery Type:	CR2 3V 800mAh



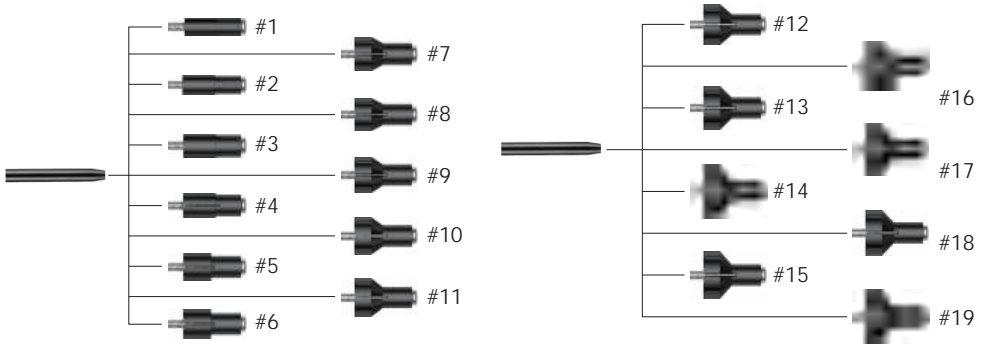

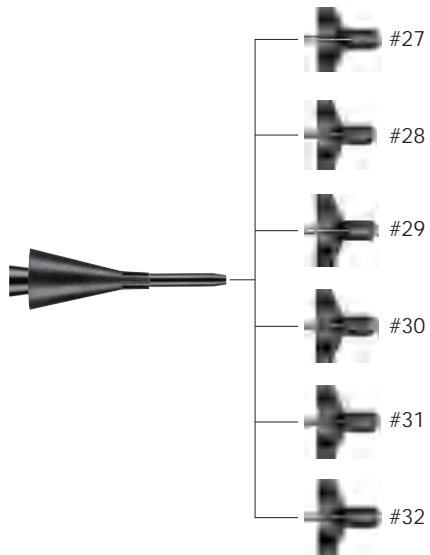
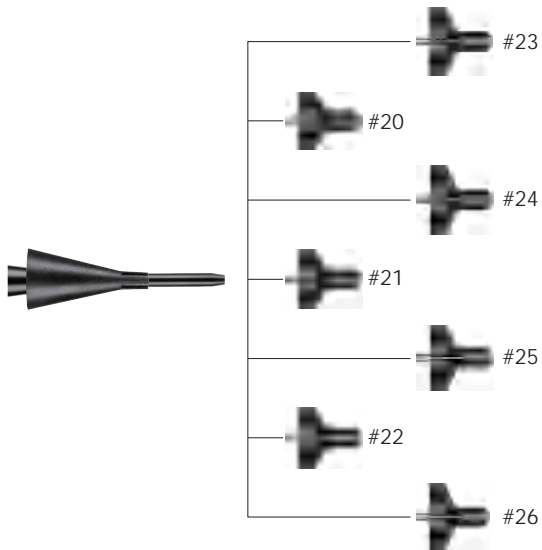















With 32 bore adapters, our laser bore sight collimator is suitable for firearms ranging from .17 to 12GA caliber. Our laser bore sight is designed to swiftly align the barrel of your rifle, pistol, or shotgun with the bullseye on your paper target, saving your time and money.

















Upgraded with 32 Adapters to Fit Calibers Ranging from 0.17 to 12GA

The size numbers on the adapters are prominently displayed and easily visible for quick reference:

 #1	 #2	 #3	 #4	 #5
.167 to .197 cal(inch) (4.24-5.00mm)	.197 to .217 cal(inch) (5.00-5.51mm)	.217 to .236 cal(inch) (5.51-5.99mm)	.236 to .256 cal(inch) (5.99-6.50mm)	.256 to .276 cal(inch) (6.50-7.01mm)
 #6	 #7	 #8	 #9	 #10
.276 to .295 cal(inch) (7.01-7.49mm)	.295 to .315 cal(inch) (7.49-8.00mm)	.315 to .335 cal(inch) (8.00-8.50mm)	.335 to .354 cal(inch) (8.50-8.99mm)	.354 to .374 cal(inch) (8.99-9.49mm)
 #11	 #12	 #13	 #14	 #15
.374 to .394 cal(inch) (9.49-10.00mm)	.394 to .413 cal(inch) (10.00-10.49mm)	.413 to .433 cal(inch) (10.49-10.99mm)	.433 to .453 cal(inch) (10.99-11.50mm)	.453 to .472 cal(inch) (11.50-11.98mm)
 #16	 #17	 #18	 #19	 #20
.472 to .492 cal(inch) (11.98-12.49mm)	.492 to .512 cal(inch) (12.49-13.00mm)	.512 to .531 cal(inch) (13.00-13.48mm)	.531 to .551 cal(inch) (13.48-13.99mm)	.551 to .571 cal(inch) (13.99-14.50mm)

 #21	 #22	 #23	 #24	 #25
.571 to .591 cal(inch) (14.50-15.01mm)	.591 to .610 cal(inch) (15.01-15.49mm)	.610 to .630 cal(inch) (15.49-16.00mm)	.630 to .650 cal(inch) (16.00-16.51mm)	.650 to .669 cal(inch) (16.51-16.99mm)
 #26	 #27	 #28	 #29	 #30
.669 to .689 cal(inch) (16.99-17.50mm)	.689 to .709 cal(inch) (17.50-18.00mm)	.709 to .728 cal(inch) (18.00-18.49mm)	.728 to .748 cal(inch) (18.49-18.99mm)	.748 to .768 cal(inch) (18.99-19.50mm)
 #31	 #32			
.768 to .787 cal(inch) (19.50-19.98mm)	.787 to .807 cal(inch) (12GA) (19.98-20.49mm)			

How to use:

1

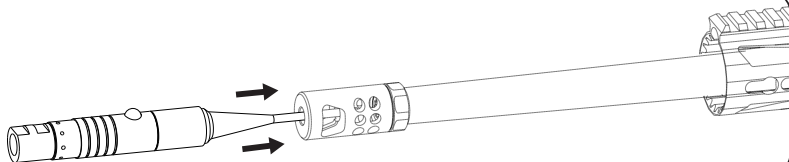

Choose a suitable plastic adapter and install the calibrator on the muzzle.

2

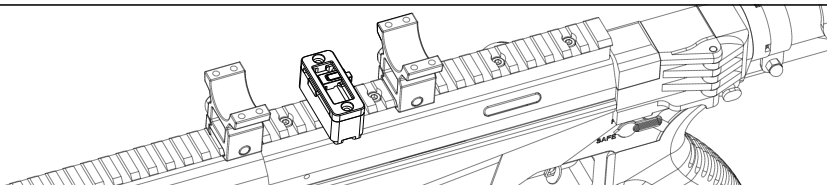

Secure the gun and place the level on the flat surface of the rail where the scope will be mounted.

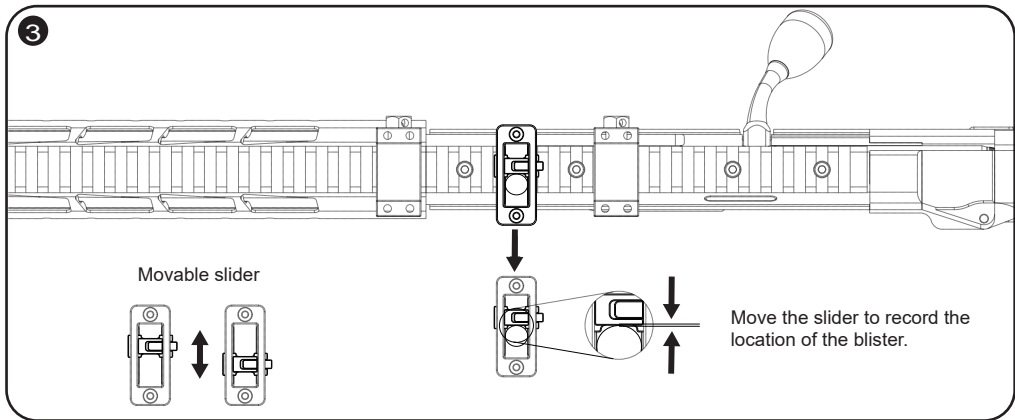

Secure the gun and place the level on the flat surface of the rail where the scope will be mounted.

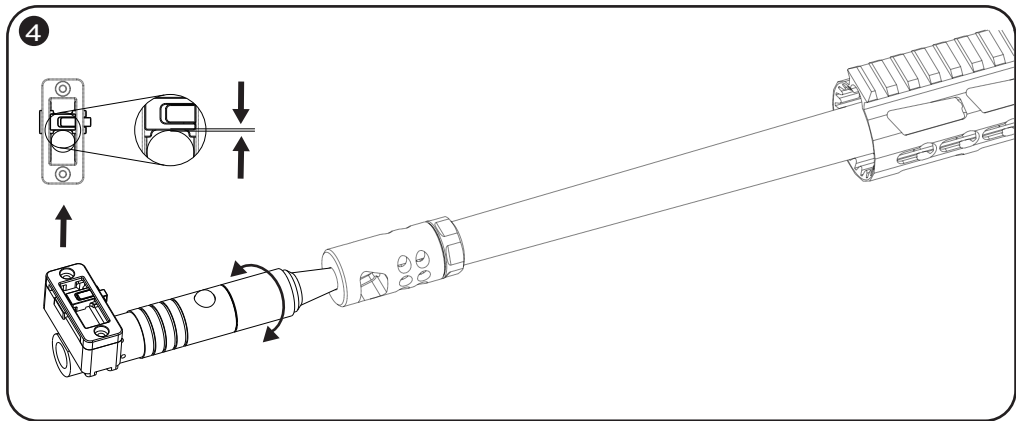

Move the level to the flat surface at the front of the calibrator and turn the calibrator so that the bubble moves to the same position recorded.

Calibration and debugging steps:

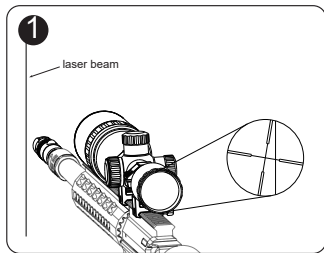

Install the scope to the bracket, but do not need to tighten the screws completely, so that the scope can move back and forth and rotate, light the laser, pick up the gun, and project the laser line to the wall 5 meters away, adjust Find a suitable distance between the front and rear position of the scope and your eyes, and observe the laser line projected on the wall through the scope.

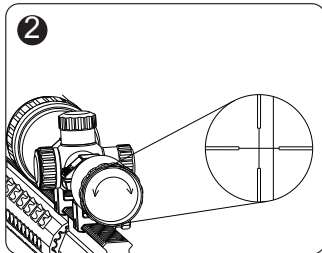

Turn the scope so that the vertical line of the scope's reticle is roughly parallel to the laser line.

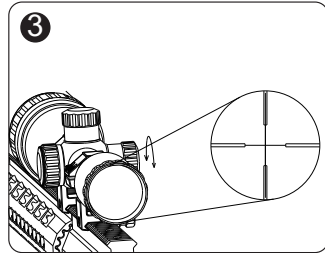

Use the windage knob to adjust the scope to move the vertical line of the reticle near the laser line, and perform rotational fine-tuning and windage fine-tuning to make the vertical line of the reticle completely coincide with the laser line. After completing the adjustment, tighten the bracket screws as required.

Placing Our Laser Dot on Your Paper Target:

Adjust your fixed sight so that our laser dot is on top of the front sight blade. This is often referred to as "the pumpkin on the post".

- ① If you are using a red dot sight on top of your barrel, make adjustments to align your dot with our laser's sight dot.
- ② If you are using a scope, again, make adjustments to align the crosshairs with our laser's sight dot.

The barrel of your gun is now bore sighted in with your sights. Follow this up by sighting your gun in with live bullets. This is done by using your adjustments again, and by walking your gun's bullet holes into the center of the bullseye.

You now have achieved "Accuracy". Your gun now shoots exactly where the sights are aimed.

Increasing the distance between your paper target and yourself during this process can further enhance your accuracy.

